

**Lydd Kart Circuit**  
**IKR RACE MEETINGS**  
**Rules and Regulations Summer 2024**

**Published Copy – Issue 002**

**Issue Date 25<sup>th</sup> March 2024**

## **Section 1. General.**

**1.1.** Lydd Kart Circuit (LKC) Independent Kart Racing (IKR) race meetings are run at a Motor Sport UK licensed circuit and where appropriate general, published motor sport rules will apply. These rules and regulations may be changed, clarified, varied or amended at the discretion of the Clerk of the Course (CoC) and or LKC following consultation with the competitors. If a change is made adequate notice will be given so that Drivers/Mechanics and teams can make changes to comply with the new rules and regulations. Any changes will be notified on the LKC Website (See <https://www.lyddkartcircuit.com/>) Matters affecting safety will take immediate effect.

If a competitor has any doubts or questions regarding competing in this series of races please ask do not assume!

**1.2.** The 2024 IKR Summer Series Race events will take place over the weekends of:

6th/7th April 2024	Classes as detailed below.
4th/5th May 2024.	Classes as detailed below.
1st/2nd June 2024	Classes as detailed below.
6th/7th July 2024	Classes as detailed below.
1st/2nd September 2024	Classes as detailed below.
5th/6th October 2024	Classes as detailed below

**1.3.** Each event will cater for the following Kart Classes:

Bambino and Bambino Might-E - Race not Time Trial.

Honda Cadet 160 - With Honda GX160 engine.

Honda Cadet 200 - With Sealed GX200 engine.

Rotax Micro Cadet - With sealed, restricted Rotax FR125 Junior engine.

Rotax Intermediate Max - With sealed, restricted Rotax FR125 Junior engine.

Rotax Junior Max - With sealed Rotax FR125 Junior engine.

Senior Rotax Max 162 - With sealed Rotax FR125 engine.

Senior Rotax Max 177 - With sealed Rotax FR125 engine.

The organisers reserve the right to mix classes dependant upon the size of entry in each class.

Other classes may be invited to take part in any of the events detailed above on a one off basis but must provide their own technical regulations.

Individual class Technical Regulations will be in accordance with those which are generally, nationally accepted for 2024. Detailed class specifications/regulations will be provided upon request. A summary of class requirements with respect to tyres, weights, number plate colours etc. is provided at Appendix B to these regulations.

**1.4.** All competitors must be registered by entry. By entering an event and registering you accept, understand and agree to abide by these rules and regulations together with any requirements of specific event final instructions or similar.

**1.5.** Entry/registration for an event must be carried out on-line. Entry should be made by 23.59 hrs. on the Friday evening prior to an event. Late entries may be accepted at the discretion of LKC. The Entry fee for LKC club members is £130 for both days or £60 for Saturday Practice and £70 for Sunday Race. For non-members the fees are £140 for both days or £65 for Saturday Practice and £75 for Sunday Race.

**1.6.** Drivers under 18 years must have their online entry countersigned by a parent or guardian who must be present for the complete meeting. A competitors legal parent or guardian may assign their responsibility to a third party but must provide the Secretary of the Meeting with a written delegation of authority signed by both themselves and the person to whom authority is delegated. Such authority is only valid for the one event to which it refers.

**1.7.** It is mandatory for all drivers to attend any drivers briefing called by the Clerk of the Course. A roll call may be called to confirm attendance. Failure to attend a drivers briefing may result in a penalty being applied.

**1.8.** By signing on, all competitors, parents and or guardians understand and accept all risks involved at a practice or race day. It is also the responsibility of the competitor to explain the risk involved to anyone associated with them. (IF IN DOUBT PLEASE SEE AN OFFICIAL).

**1.9.** Unless otherwise advised, Grid positions will be determined as a result of timed qualifying. The club reserves the right to amalgamate classes with the fastest at the front. In this event, ALL karts will start on the same lights. Where time permits, classes with a minimum of 6 entries will get their own race.

**1.10.** Race format will be either: a pre-defined number of laps or a predetermined time plus one lap (duration to be advised in the event final instructions or determined on the day if conditions demand it.).

**1.11.** Dogs must be kept on a lead at all times and away from the track and any fouling must be cleaned up. Failure to do so will result in a ban from the circuit.

**1.12.** Any driver under the influence of alcohol or drugs will not be permitted to race. If you sign on we have the right to ask for you to be breathalysed or drug tested. A refusal will result in not being allowed to participate in the meeting.

**1.13.** All new starters must inform the competition secretary that they are a new starter (Novice) and must display novice plates. If there is no timed qualifying, they will start at the back of the grid for their first 3 meetings or until the CoC considers they are competent to race from a predetermined grid. Failure to inform the secretary may result in exclusion from the meeting.

**1.14.** The driver is responsible for the actions of his mechanics and anyone associated with him/her. Anyone being abusive, using foul language or threatening behaviour will be asked to leave the circuit, and may be asked to appear in front of the organisers who have the rights to impose a ban and inform other circuits.

1.14.1 In this respect it is a condition of entry that ALL competitors understand and comply with the requirements of the Race and Respect Policy of Lydd Kart Circuit. A copy of this policy is attached for reference at Appendix D of this document.

**1.15.** Children must be supervised at all times. Scooters, bikes and ball games are not permitted anywhere within the paddock once practice/race has commenced. The organisers reserve the right to confiscate equipment until the end of the day.

**1.16.** It is your responsibility to ensure your awnings are securely fastened down, also please consider your neighbours when positioning your generator. All generators must be turned off by **10.00pm**.

**1.17. Proof of age:** - May be required for all minors (Under 18 years – e.g. Birth Certificate). A competitor entering any class who appears to be under age for that class may be asked to provide proof of age.

**1.18.** Once the meeting has started if you cannot continue, please inform the competition secretary so grids can be reconfigured if necessary.

## **Section 2. Safety**

### **General**

**All safety rules are mandatory and it is a competitors sole responsibility to ensure that their kart and equipment is safe, technically compliant and fit for purpose.**

Generally, our scrutineers will only be checking compliance with the appropriate class technical regulations.

The following safety equipment **must** be worn during all practice and race sessions.

- Helmets: CIK/MSUK/Snell specification racing helmets. UK road legal motorcycle helmets are not permitted.  
All competitors of 15 years or less MUST use a specifically designed Lightweight helmet Complying with Snell – FIA CMR 2007 or 2016, or Snell – FIA CMS 2007 or 2016. The maximum weight of the helmet should not exceed 1,550g.
- Suits: CIK homologated with no limits on homologated date.
- Footwear: Racing boots with ankle protection.
- Gloves: CIK/MSUK/Snell racing gloves.

ALL safety equipment must be in good condition with no significant damage that would reduce the item's ability to protect the driver.

All competitors must have access to a fire extinguisher of a type suitable for the type of fire risk appropriate to their kart and equipment type. For those in "team awnings" or awnings with all sides covered, this must be placed near the door of entry and exit.

It is also highly recommended that all entrants carry a simple first aid kit, containing plasters, medical tape, scissors, medical bandages and disinfecting spray or wipes.

**2.1.** Irrespective of the foregoing, at the discretion of the officials of the meeting, karts and **protective** equipment including helmets, gloves and footwear may be inspected before practice. All karts and equipment must be registered electronically by completing the on-line scrutineering declaration before commencing practice, qualifying or racing. Failure to present a kart or equipment for pre-event scrutineering when requested may result in a penalty being applied. Number plates must be fitted front, rear and both sides and must be kept in good condition. You must also display the correct number and coloured plate for your class.

**2.2.** Drivers must ensure that helmets and race suits are fully fastened and visors must be down at all times whilst on circuit.

**2.3.** One driver and one mechanic only allowed on the Dummy Grid or in Parc Ferme (Scrutineering Area). In certain circumstances mechanics already on the grid will be allowed to help other competitors. You must be in your grid position on the dummy grid by the last lap of the preceding race otherwise you may be put to the back of the grid.

**2.4.** Drivers must without delay obey all flag signals given by officials. Drivers are responsible for learning all flags and their meanings before going out on circuit. If you are in doubt please ask before racing.

**2.5.** Marshals will not leave their posts unless they are specifically instructed to do so by the Clerk of the Course to assist drivers for safety reasons..In the event that you are forced to stop during a race, please put your kart into a safe position and retire to the nearest Marshals post until the end of the race.

**2.6. The Race Control/Race Timing room is out of bounds during racing.**

**2.7.** During racing the centre of the track is out of bounds except for officials. Signed on Bambino, Cadet, Intermediate or Junior parents or guardians are permitted at the discretion of the CoC and must wear a high visibility vest.

**2.8.** Filming, Timing or Coaching of drivers from the centre of the track is not permitted. Failure to comply may result in a competitors exclusion from heat/final and they may not be allowed back on track for the day.

**2.9.** No radio communication is allowed on race day to any driver on the circuit.

**2.10.** Recovery of karts from track is not permitted during racing and will be allowed at the end of the race at the discretion of the Clerk of the Course.

**2.11.** Tyre warming is not permitted on the dummy grid (Rear wheels must not be lifted from the ground with the engine running). A breach of this rule may result in removal from the grid/race.

2.11.1 Aggressive tyre warming during the roll up lap is not permitted and may incur a 5 second time penalty applied at the end of the race.

**Note:** A competitor who spins their kart when weaving during roll up laps or entering the circuit from the dummy grid will be considered to be weaving too aggressively.

### **Section 3. Driving Standards**

**3.1.** If a driver leaves the circuit they must re-join only when it is safe to do so. Failure to comply will result in a penalty at the discretion of the CoC.

**3.2.** Anyone re-joining in an unsafe manor may be black flagged and excluded from that race.

**3.3.** Passing under a stationary yellow flag will result in a 10 second time penalty being applied at the end of the race. Passing under a waved yellow will result in a 20 second time penalty being applied at the end of the race. A driver in breach of this regulation twice in a race will be shown the Black Flag.

**Note:** Giving a place back after an offence is committed will have no effect on these penalties for which there is NO appeal.

**3.4.** When a race has finished a yellow flag will be shown at the next post. Racing must stop when you have taken the chequered flag. Drivers must slow to a steady pace. DO NOT overtake on the return to Parc Ferme /Pit Lane. Drivers not obeying this rule and who continue to drive at excess speed will be disqualified from that race and further action may be taken by the Clerk of the Course.

**3.5.** In the event of a Red Flag being shown, ALL competitors must cease racing and stop in a designated location on the track. Generally this will be along the back straight immediately before Marshal Post 6. Karts **should be stopped, line astern to the left-hand side of the track** to allow room for the Ambulance or other rescue vehicle to pass if necessary. If conditions demand it, competitors may however be requested to stop at another location on the track as directed by a marshal or other on-circuit official.

3.5.1. Whilst parked following a Red Flag, karts will be considered to be under Parc Ferme conditions and NO repair or other work can be carried out. Mechanics, Parents etc. are NOT permitted onto the circuit to restart karts or for any other purpose until directed by the Clerk of the Course.

3.5.2. Any kart causing a red flag incident may only take part in the restart after being inspected by the scrutineer and at the discretion of the CoC.

3.5.3. In the event of a race being stopped:

- (a) If less than 2 laps have been completed by the leader at the time of the Red Flag being displayed, Then the race will be re-run in its entirety with all competitors starting in their original starting (grid) positions.

- (b) If less than 75% of the race time/distance has been completed by the leader at the time that the Red Flag is displayed, then the race will be restarted with competitors in single file. The starting order shall be in the finishing order of the last FULL Lap completed by ALL competitors still proceeding under their own power, when the red flag was first displayed.

Drivers one or more laps down at the time of the red flag will be put in their correct positions, behind the rest of the field.

The finishing order at the end of the second part of the race shall be deemed to be the result of the race.

- (c) If 75% or more of the race distance has been completed by the leader at the time that the red flag is displayed then the race shall be deemed to have ended.

The race results shall be declared as the order of finishing on the last full lap completed by ALL karts still proceeding under their own power before the red flag was displayed, followed in classification by non-running karts on a roll-back of laps basis.

**3.6.** All karts involved in a serious (Red Flag) incident must be inspected by the scrutineers before being allowed back on circuit.

**3.7.** Starts are to be 2 x 2 formations with either a Standing Start or Rolling Start dependant upon class. Generally, the Cadet, and Bambino Classes will use a standing start. ALL other classes will use a rolling start.

During the rolling up laps (of which there will generally be only one unless advised at the drivers briefing), drivers are permitted to regain their place up until they reach the yellow flag at post 6. If the correct pace/speed is not obtained by 2 rolling laps the offending drivers may be put to the back of the grid.

**All karts must remain between the tramlines or in their grid box** until the lights **GO OUT**. Anyone failing to comply may receive a 3 second time penalty. Note that this is judged by the **Clerk of the Course** who is a **Judge of Fact** against which there is NO appeal. Race finishing order is determined by the **Timekeeper** who is also considered as a **Judge of Fact**.

The race start will be as C.I.K (**as lights go out** the race starts).



**3.8.** All drivers must obey any mechanical defect flags given within 2 laps. The circuit has NO facility to carry out mid-race repairs therefore the driver should return to Parc Ferme. Failure to comply will result in exclusion from that race. Competitors should note that a mechanical defect flag will only be displayed at the start/finish line and on the start line, overhead, Digi-flag. Similarly any driver warning flags will be displayed at these locations only. When displayed these flags will be displayed together with the number of the competitor(s) to which they refer. Any driver who receives more than 2 warning flags during a race may be shown the Black flag.

**3.9.** Running engines are only allowed in the permitted area for a max of 10 seconds. Bambino can be run up to 1 minute. You may start your engine in your own pit area but not allowed to rev the engine also engine must not be run whilst moving a kart through the paddock failure to comply may result in exclusion from the meeting.

**3.10.** The decision of the Clerks of the Course on all matters will be final. Where appropriate witness(es) may be called. The Clerk may exclude a driver from the heat/final or the meeting or impose a penalty as detailed in Appendix A to these regulations. Note that this is not a complete list and the Clerk of the Course may impose further penalties as deemed appropriate.

3.10.1 If a competitor is unhappy with the decision of the Clerk of the course they may appeal the decision within 30 minutes of that decision being made or 30 minutes of the result of a race being posted (whichever is the sooner).

Protests **MUST** be lodged in writing with the Secretary of the Meeting who will note the time of lodging.

**3.11.** Time keeper will be **Judge of Fact** regarding race finishing order.

**3.12.** Driving in a manor not deemed to be of a safe, or acceptable standard or in the spirit of the sport may result in a ban with the competitor required to appear in front of the organisers.

**3.13.** Officials are volunteers, please remember the meetings cannot run without them so please show respect. Failure to obey the instruction of an official will be reported to the CoC and a penalty may be imposed.

**3.14.** Foul and abusive language, physical violence, threat of physical violence. intentional damage to any circuit or personal property will result in a ban with the competitor required to appear in front of the organisers. All local clubs/circuits will be informed of a guilty verdict.

**3.15** Dishonoured payment, the competitor must make good plus any charges incurred by the following meeting. Failure to do so the organisers reserve the rights to inform all local clubs.

**3.16** A table of the more common offences and penalties is provided at Appendix A to these Regulations. Please note that this is not a complete list and that the Clerk of the Course may add or increase penalties for offences as he/she deems appropriate.

## **Section 4 Kart Technical**

**4.1.** All karts must comply to the nationally published class rules and regulations (The 2024 Karting Yearbook) or the specific class regulations indicated at Appendix B of this document, at all times on race days. Karts found to be non-compliant technically at post race scrutineering will incur a penalty for their driver. Karts may be weighed at the end of each race. If found underweight the competitor will be excluded from the results of that race. There is no appeal or protest against this.

**4.2.** Two engines and one chassis may be scrutineered/registered for all classes. Prior to the commencement of timed qualifying a competitor may substitute an engine or chassis having first obtained the permission of the Chief Scrutineer. During the meeting, in the event that a chassis is damaged beyond repair, on the recommendation of the Chief Scrutineer and at the discretion of the Clerk of the Course, a second chassis may be permitted.

**4.3.** Whilst it is the responsibility of the driver and mechanic to ensure the kart remains in a safe race worthy condition for the duration of the meeting, the organisers may ask for the kart, racewear/PPE etc. of an individual competitor, group or class of competitor or all competitors to present themselves and their equipment for safety checks prior to the commencement of practice. This will generally be advised in the event final instructions. If in any doubt about the suitability of your equipment, please ask for it to be inspected by the event scrutineers.

**4.4** If a wet meeting is declared only karts fitted with wet tyres and complying with class regulations, e.g. rear wheels outside of pods, as listed for that class with a minimum 2mm tread depth may start the race. See also Appendix C regarding Pods and Rear Bumpers when in wet configuration.

**4.5.** All ballast weights **must be secured by 2 fixings** e.g. 8mm diameter bolts with self locking nuts. Individual pieces of ballast must weigh no more than 5Kg. The maximum ballast that may be carried on the kart is 30Kg.

**Tie wraps, Velcro etc. are not acceptable neither is loose ballast, fitted inside the seat and retained only by the drivers body.**

Anyone carrying "Lead", or other material as ballast, on their person will be excluded from that race.

All tyres, bodywork and engines should be checked after each heat for damage and security.

**4.6.** Timing is by AMB/Mylaps transponder. It is the driver's responsibility to have one fitted. There is a limited amount to hire at £10.00. A UK driver's licence or valid bank card

may be required as deposit. If you break, lose or misplace a transponder you will be required to pay for a new one.

- 4.6.1. All transponders **MUST** be mounted on the back of the seat and be fitted for practice, timed qualifying and each race on race day. It is important that competitors ensure that the transponder is fitted to the kart for practice as this session is used to confirm that the transponder is working correctly.
- 4.6.2. Transponders hired from the circuit should be collected from the circuit reception area by 9.00am in order to allow the relevant information to be loaded onto the timing system prior to the commencement of practice. At the end of the final race of the day, a circuit official will collect hired transponders in the scrutineering area. If you are unable to complete the event and leave the circuit for any reason please return the transponder to the Circuit reception area.

**4.7.** On returning to Parc Ferme at the completion of each race or timed qualifying session, Karts may be randomly inspected by the scrutineer to ensure compliance with the rules and regulations.

**4.8.** Tyres must be of the make and type stipulated by the class rules and summarised at Appendix B of this document. Tyres will be marked or bar coded and their details recorded on the event Scrutineering section of the Trakentries Race Management (Entry) Portal. The organisers may use a Bar Code reading App. to confirm the details of each tyre notified by a competitor. Alternatively the scrutineers may mark tyres at the completion of Timed Qualifying. A change of tyre prompted by tyre failure must be approved by the Chief Scrutineer and the damaged tyre left in scrutineering until the end of the meeting.

- 4.8.1 Competitors are reminded that they are only allowed 1 set of slick tyres per meeting. (Note that a “meeting” consists of timed qualifying and any heats, pre-finals or grand finals. It does not include practice for which a competitor may use any tyre of their choice).
- 4.8.2 A competitor may use more than one set of wet tyres for a meeting.
- 4.8.3. Any use of tyre softener or any other means, known or unknown, to gain an unfair advantage from tyres will result in an exclusion from the event.

**4.9.** Only unleaded pump fuel complying with the specification BS-EN 228 (No AvGas/100+ Octane fuel or additives are allowed) and oil listed by C.I.K. are permitted. Anyone using any unlisted oil must have it cleared by the scrutineer. Failure to do so may

result in an exclusion from the event and a possible ban. The organisers reserve the right to collect fuel samples and send them away for testing.

**4.10.** With the exception of Bambino, all karts must be fitted with “Drop Down” nose cones. Penalties will be applied in accordance with Appendix A, if during post race scrutineering it is found that a nose cone has dropped during a race or timed qualifying.

**4.11.** All engines /Karts will run to the specifications as supplied by the following: J.A.G/Rotax, and Honda (ABkC/RPM/Anderson-CSK). Any exceptions will be published in the class rules.

All Honda GX200 engines used in Cadet 200 and Intermediate Honda classes must be as supplied and sealed by RPM or any Anderson-CSK approved supplier. LKC also reserve the right to ask a competitor to change an engine(s) from one of their pool of RPM supplied units at any time during an event. (Further details of these processes are included in the Class Specific Technical Regulations. – Available separately).

**4.12.** The organisers reserves the right to have an engine sealed and sent away to be checked for eligibility. If the engine proves to be legal then all cost will be paid by the organisers. If the engine proves to be illegal then all cost including carriage will be the responsibility of the competitor.

**4.13.** Competitors have the right to protest another competitor’s engine. £250.00 must be deposited with the organisers. This is returnable in full should the protest be successful, If the protest fails this fee will be used towards the rebuild labour cost with any balance returned. Any protest shall be lodged in writing with the Secretary of the meeting after the final race has started but before the final race has finished (by either chequered or red flag). The protest should be accompanied by the appropriate fee.

**4.14.** The fitting of “Go-Pro” or other similar recording devices is not permitted during any official practice, timed qualifying or racing.

**Section 5 – LKC 2024 Summer Championship.**

**Unless otherwise specified in the Final Instructions for an Event, the race day format will comprise a practice session and a timed qualifying session. These will be followed by 1 heat, a Pre-Final and a Grand Final all of which will provide point scoring opportunities as follows:**

**5.1** The LKC Summer Championship will be contested over 6 events (April 2024 to July 2024 inclusive plus September and October 2024 – Note there is no event in August 2024) a competitors best 5 event scores to count towards their final championship position. See also 5.3.

**5.2** Championship Points will be awarded for the finishing position achieved in both the Heats, Pre-Final and the Grand Final at each round in accordance with the following schedule:

**5.2.1 Heats and Pre-Final**

Points will be awarded to each competitor based on their finishing position in each Heat as follows:

1st- 25 points; 2nd- 23 points; 3rd- 22 points; 4th- 21 points; 5th- 20 points, 6th- 19 points; 7th- 18 points, 8th- 17 points; 9th-16 points; 10th-15 point; 11th-14 points; 12th-13 points; 13th-12 points; 14th-11 points; 15th-10 points; 16th- 9 points; 17th- 8 points; 18th- 9 points; 19th- 6 points; 20th- 5 points; 21st- 4 points; 22nd- 3 points; 23rd- 2 points; 24th- 1 point.

**5.2.2 Grand Finals.**

Points will be awarded to each competitor based on their finishing position in the Final as follows:

1st-50 points; 2nd-45 points; 3rd-43 points; 4th-41 points; 5th- 39 points, 6th- 37 points; 7th-35 points, 8th-33 points; 9th-31 points; 10th-29 point; 11th-27 points; 12th-25 points; 13th-23 points; 14th-21 points; 15th -19 points; 16th- 17 points; 17th-15 points; 18th 13 points; 19<sup>th</sup>- 11 points; 20th- 9 points; 21st-7 points; 22nd-5 points; 23rd –3 points; 24th -1 point.

5.2.3 In the event that a competitor does not start a race they will receive a Zero (0) points score for that race only.

5.2.4 In the event that a competitor starts a race but is a non-finisher they will be awarded points for 1 place lower than if they had finished last in that race. For example if a heat has 12 starters, a non-finisher will be awarded points for 13<sup>th</sup> position i.e. 12 points.

**5.3.** For the Championship the winner of each class will be the competitor with the highest points from their 5 best event points totals. If an event(s) is cancelled for any reason then a competitors points totals from all of the events actually run will be counted.

5.3.1. In the event that a competitor is excluded by the organisers, from an event by reason of: Scrutineer Non-Compliance Report (See 2.1, 4.1 and 4.6), Using Foul or Abusive Behaviour or Physical Assault (See 1.14, 3.12 & 3.14), Failure to Obey the Black Flag for more than 2 laps (See 2.4), Failure to Obey an Official of the Meeting (See 3.13), or such similar then they can not use the score from that event as their dropped score. Exclusion from an event will result in a zero score being recorded for the whole event.

**5.4.** In the event of a points tie after the final round, the position will be determined by considering a competitors dropped round score. If that is inconclusive, the competitor with the highest number of first places in finals, then successively descending positions will be used to decide the Winner. If this still results in a tie the results from the last round will be used to determine the final championship positions. In the event of the Final not being run for whatever reason, final results from the Pre-Final will be used as the final result.

**5.5.** Individual event trophies will be allocated 1 in 4 entries in each class (or at the organiser's discretion).

**5.6.** Championship trophies will be calculated from the number of drivers completing a minimum of 3 rounds. Based on an average entry of 1 to 4 one trophy will be allocated; for 6 to 8 two trophies; for 9 to 12 3 trophies and so on.

**Appendix A Summary of Common Race Penalties**

<b>Regulation Reference</b>	<b>Infringement/Description</b>	<b>Penalty</b>
3.10 & 3.12	Gaining an Unfair Advantage	5 place penalty
3.2, 3.10 & 3.12	Driving in a manner incompatible with general safety	Race Exclusion
3.4	Contravention of Flag Signal (Black/Yellow or Yellow) before or after a race.	5 second time penalty
3.3	Contravention of Stationary Flag Signal (Black/Yellow or Yellow) during a race	10 second time penalty
3.3	Contravention of Waved Flag Signal (Black/Yellow or Yellow) during a race	20 second time penalty
3.3 & 3.8	Contravention of any Flag Signals (Yellow, Yellow/Black or Mechanical Defect) twice in a race	Black Flag
3.7	Starting procedure infringement	3 second time penalty
3.8	Driver receiving the Warning Flag (Black and White) 3 times or more during a race.	Black Flag.
2.4	Contravention of the Black Flag for more than 2 laps	Race or Meeting Disqualification
1.14, 3.12 & 3.14	Abusive Language, Behaviour or Assault	Race or Meeting Disqualification and possible circuit ban. Other circuits/clubs notified
1.8	Failure to attend any drivers briefing called by the Clerk of the Course	Will not be allowed to compete in Heat 1
3.13	Failure to obey an official of the meeting	Race or Meeting Disqualification
4.1	Scrutineer Non-Compliance Report (Kart or component ineligible)	Race or Meeting Disqualification (No Appeal)
4.1	Underweight	Race Disqualification (No Appeal)
2.1, 4.1 & 4.6	Failure to Report for Scrutineering	Race or Meeting Disqualification
4.9	Incorrectly positioned Front Fairing (Nose Cone Dropped)	Race – 5 seconds Penalty Qualifying – Fastest lap discounted
	Attempting to tamper with or reattach the front fairing during a race or qualifying	Race Disqualification
	Intentionally re-attaching the front fairing after the chequered flag and before scrutineering	Meeting disqualification and potential circuit ban.



**Appendix B – Summary of Kart Class Technical Regulations**

<b>Lydd Kart Circuit - Independent Kart Racing - Summary of Class Technical Regulations</b>							
<b>Class</b>	<b>Number Plate/ Number</b>	<b>Class Weight (Driver Minimum Weight) Kg</b>	<b>Ages</b>	<b>Tyres (Dry)</b>	<b>Tyres (Wet)</b>	<b>Engine</b>	<b>Comments</b>
Bambino See Note (i)	Orange/ Black	71	6 to 8	Le Cont MSA04	Le Cont MSA04	Sealed Comer C50	Blue and Green Tagged Engines are permitted and will race together
Bambino Might-E	Blue/ White	83 (21.5)	6 to 8	Le Cont MSA04	Le Cont MSA04	MSUK Homologated electric powerplants only	
Honda Cadet 160 See Note (ii)	Yellow/ Red	103 (27)	8 to 12	Vega Cadet UK	Vega WM1 CIK	Honda GX160	One Class only. No separate Rookie/Novice Class.
Honda Cadet 200 See Note (ii)	Yellow/ Red	103 (27)	8 to 12	Vega Cadet UK	Vega WM1 CIK	Sealed Honda GX200	Engine supplied by RPM or other similar Anderson- CSK Motorsport authorised vendor
Rotax Micro Cadet	Yellow/ Black	105 (28)	8 to 11	Vega Cadet UK	Vega WM1 CIK	Sealed Rotax FR125	Restricted version of Rotax FR125 Junior Engine
Rotax Intermediate Max	Yellow/ Black	115 (33)	10 to 13	Mojo C2 CIK	Mojo CW CIK	Sealed Rotax FR125	Restricted version of Rotax FR125 Junior Engine
Honda Intermediate	Yellow/ Red	110 (33)	10 to 13	Dunlop SL3 MSUK	Dunlop KT3	R200 variant of GX200 Engine	Engine supplied by RPM or other similar Anderson- CSK Motorsport authorised vendor
Rotax Junior Max See Note (iii)	Red/ White	145 (40)	13 to 16	Maxxis Sport	Mojo W5 CIK or Maxxis SLW	Sealed Rotax FR125	Junior version of Rotax Senior Max (i.e No Power Valve fitted)
Rotax Max 162	Blue/ White	162	16 +	Maxxis Sport	Mojo W5 CIK or Maxxis SLW	Sealed Rotax FR125	
Rotax Max 177	Green/ White	177 (80)	16+	Maxxis Sport	Mojo W5 CIK or Maxxis SLW	Sealed Rotax FR125	

## NOTES:

Karts must comply with the technical regulations specific to each class as detailed in the 2024 Karting Yearbook or detailed specifically in this Appendix.

(i) Bambino karts powered by Comer Petrol engines will run to the 2023 Karting Yearbook regulations.

(ii) Competitors may use either a 950mm chassis complying with the current MSUK or CIK regulations or a 900mm chassis that is currently homologated for the class. Details of currently homologated chassis are provided in the 2024 Karting Yearbook. Note that it is the competitors responsibility to prove eligibility of the chassis if required.

(iii) A competitor may compete in the class at 15 years of age, providing it is in the calendar year of their 16<sup>th</sup> birthday and that they have previously raced as a junior.

## Appendix C – Information on Rear Bumpers

Following release of the latest regulations released regarding the CIK type, adjustable plastic rear bumper please see the following. The requirement for coloured end pieces will be advisory for Lydd Kart Circuit events up to and including the 7<sup>th</sup> April 2024. Thereafter it will be mandatory

Rear bumpers of the fixed, solid type, plastic or steel should **ALWAYS** cover a minimum of 50% of each rear wheel at all times in wet or dry set up. The bumper should never exceed the width of the kart, this being the width of the rear wheel/tyre as at the time the kart is being raced.

The new adjustable CIK rear protection bumper must have the outside edge of the two adjustable end parts level with the outside of the wheel/tyre at all times in the dry or wet set up (in line come rain or shine).

At no time can the rear wheel be inside the outer edge of the rear bumper (this being the widest part of the kart), with the exception of TKM in the wet.

The side pods must not be outside the outer edge of the rear wheels/tyres at any time, (Except TKM in the wet).

**Please be mindful of the above when changing from slicks to wets and wets to slicks**

**If in any doubt please ask the scrutineering team before the race**

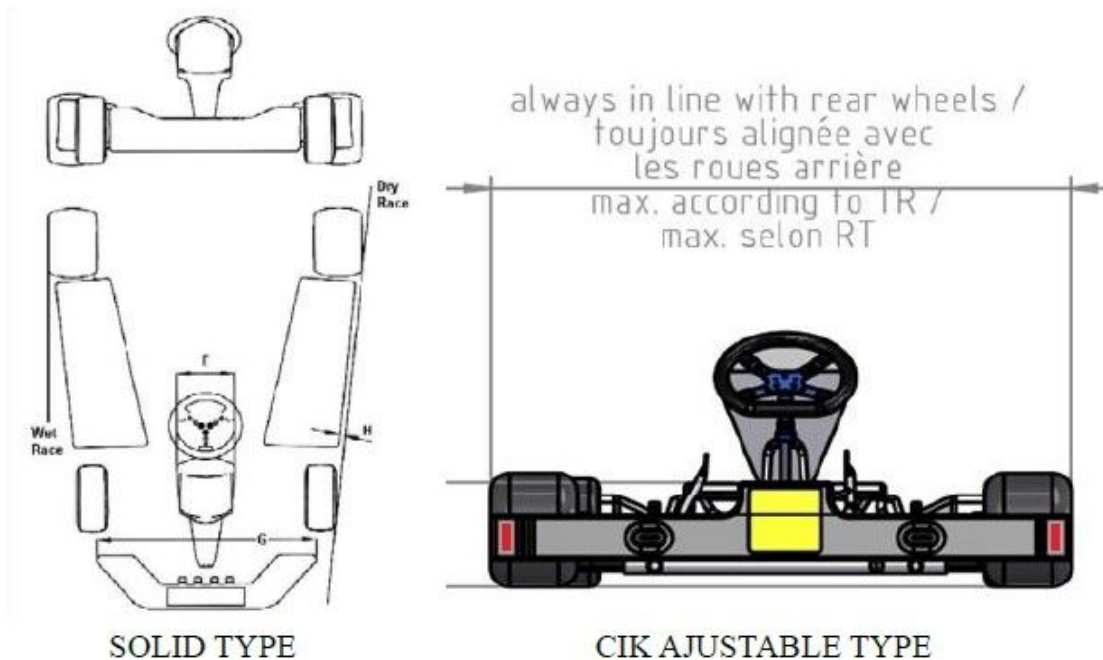

**The two adjustable outer parts of the CIK homologated rear wheel protection must have a colour that is clearly different from the main part of the rear wheel protection. This can be done by a dedicated sticker kit or by adding colour to the parts during production. (01/01/2024)**

## Appendix D – Race with Respect

Lydd Kart Circuit encourages the use of social media to promote drivers and their achievements. However, the circuit takes a very serious view on those who wish to use any social media platform to dishearten, tarnish, bully or discriminate against other users, whether they are other racers, mechanics, family/friends, officials, or championship organisers. Those who take it upon themselves to do so will be investigated by the Race Director who will decide upon the decision of penalty and/or if outside authorities need to be contacted. The offender will be given only once chance to remove the post/imaging/video material from their page before any investigation will commence. Remember, you will only cause disruption to your own racer. So, THINK before acting.

By participating in a Lydd Karting Ltd event in any capacity you agree to follow the values of the following Respect Code: LKC has a strict policy on behaviour in the paddock and on track making it a fun, friendly welcoming and positive environment. Anyone who does not meet these standards or causes disruption may have their membership revoked and banned from attending any races, membership/race fees will not be refunded.

### The Values

- Respect
- Integrity
- Self-Control
- Fair play
- Good Manners

As a competitor, you pledge to Race With Respect and:

- Contribute to a welcoming and friendly environment that ensures the safety and welfare of all participants.
- Always behave with integrity and uphold fairness in the sport; play your part in keeping the sport safe through your actions.
- Treat everyone with respect, regardless of their gender, ethnic or social background, language, religious or other beliefs, disability, sexual identity or other status.
- Recognise that we all represent the sport and therefore have a duty to be polite and respectful to all staff, officials, fellow competitors, volunteers, as well as fans and supporters.
- Respect the rules, regulations and authority of the officials of the meeting and Lydd Kart Circuit.

Any breach of these obligations may result in disciplinary action.